

Shatterproof LED Golf Ball Lamps

Available in a variety of colours

Direct retrofit for incandescent golf ball lamps

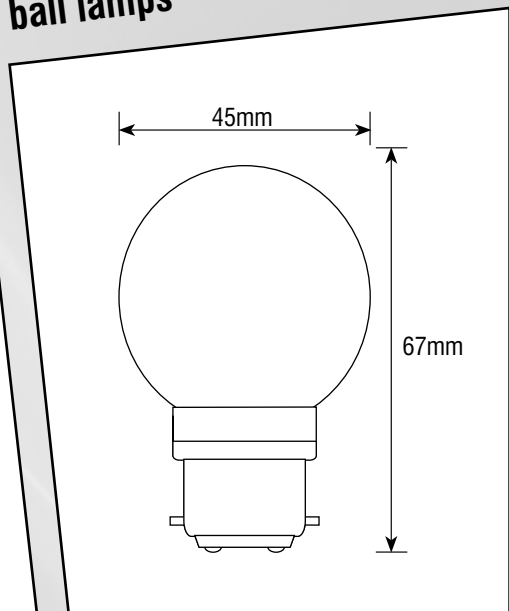

An LED direct replacement to the golf ball lamp, offering outstanding lamp life and efficiency. The range includes white, coloured and colour changing golf balls. Using no more than 1W of power these lamps have very low power consumption, and are highly efficient. They are ideal for festoon lighting, inaccessible areas and applications where long lamp life is essential.

- Like for like size replacement - direct replacement for incandescent golf ball lamps
- Available in a range of colours, and in BC or ES cap types
- Colour changing option
- 20,000 hour average life



PRODUCT CODE	POWER (W)	LUMENS	COLOUR
GOLF/LED/**/WW/P	1W	50	3000K Warm White
GOLF/LED/**/WH/P	1W	40	6000K Daylight White
GOLF/LED/BLUE/**/P	1W	N/A	Blue
GOLF/LED/GREEN/**/P	1W	N/A	Green
GOLF/LED/RED/**/P	1W	N/A	Red
GOLF/LED/YELLOW/**/P	1W	N/A	Yellow
GOLF/LED/**/CH/P	0.5W	N/A	RGB Colour Changer

** = Cap type, BC or ES

